

# HAYS COUNTY DRIVEWAY STANDARD

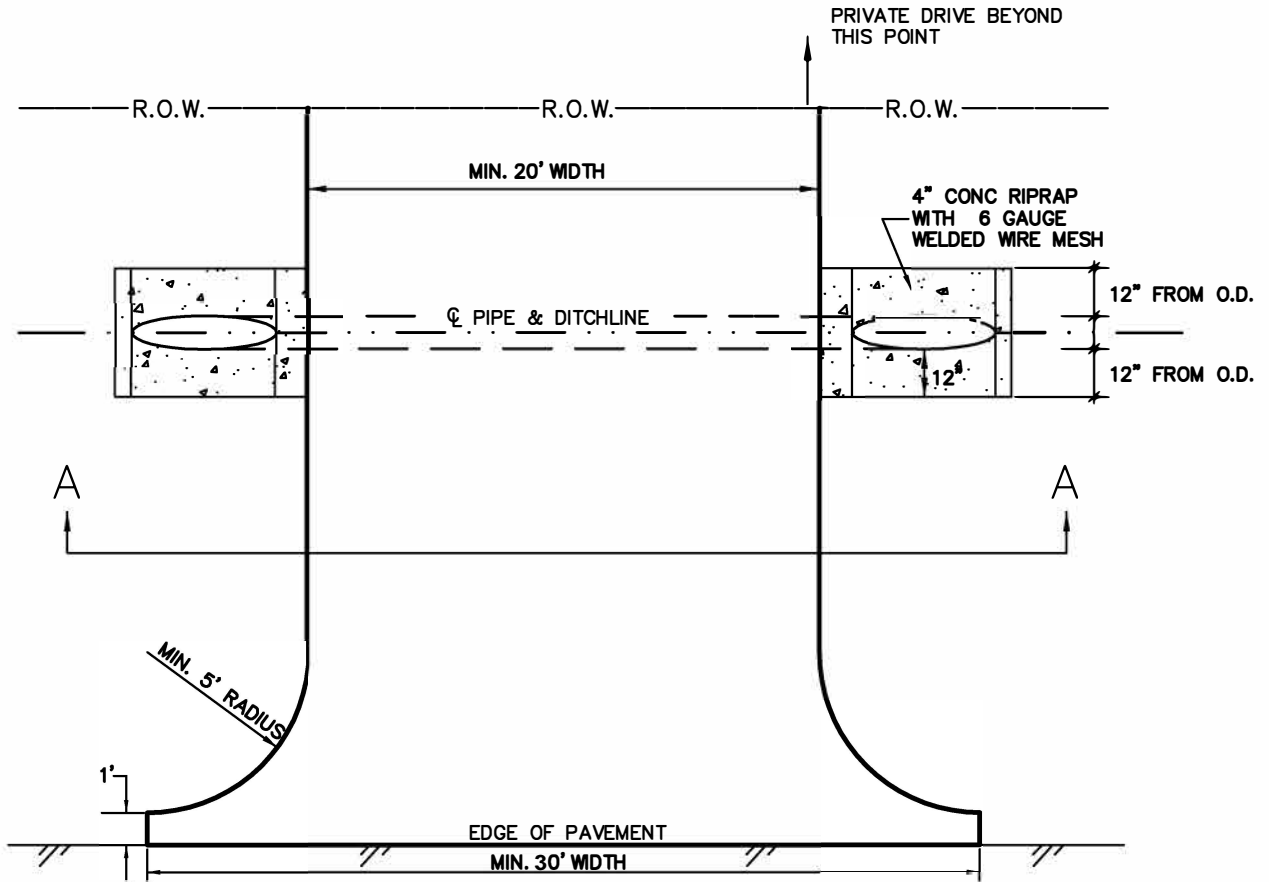

PLAN VIEW

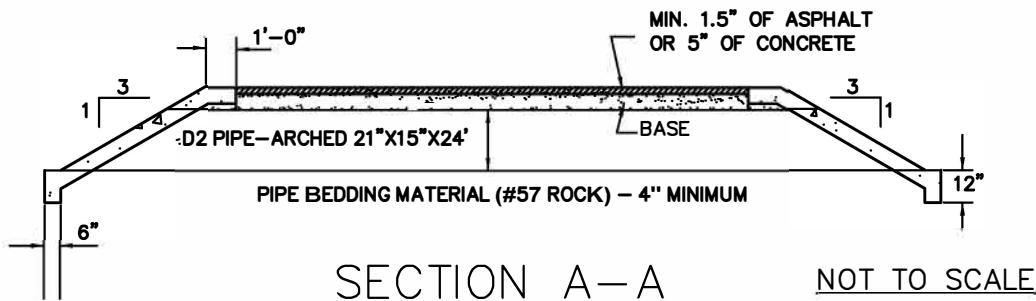

NOTES:

- Driveways shall be constructed of either 5" of class "A" concrete reinforced with 6ga welded wire mesh over 2" of compacted base, or 1.5" of asphalt over 6" of compacted base.
- SET's shall be constructed of 4" of class "A" concrete reinforced with 6ga welded wire mesh with minimum slope of 3:1.
- Culvert flowline shall match the flowline of the ditch, with a min. 4" thickness of pipe bedding material (#57 rock).
- An expansion joint shall be placed at the ROW line, with #4 smooth bars placed at mid depth 12" OC.
- Special condition may apply to pipes larger than a D2 pipe-arched 21"x15"

HAYS COUNTY, TEXAS  
RESIDENTIAL DRIVEWAY  
CULVERT-STYLE